



MANUAL DE MONTAGEM  
ASSEMBLY INSTRUCTIONS  
INSTRUCCIONES DE MONTAJE

COD BR: RP 06



## Sumário Summary Resumen

Introdução Introduction Introducción	.....	3
Antes de começar Before starting Antes de comenzar	.....	4
Evite acidentes Avoid accidents Evitar accidentes	.....	4
Dimensões e ferramentas Dimensions and tools Dimensiones y herramientas	.....	5
Identificação das peças Identifying parts Identificación de las piezas	.....	6
Acessórios incluídos na caixa Hardware included in box Accesorios incluidos en la caja	.....	7
Montagem do móvel Furniture assembly Montaje del mueble	.....	8

## Introdução Introduction Introducción

Leia atentamente este manual e siga os passos indicados para que o produto não perca a garantia e também para uma perfeita montagem.

Read this manual and follow the steps in order to keep the guarantee and also for the perfect fit.

Lea este manual y siga los pasos para que el producto no pierda la garantía y también para el ajuste perfecto.

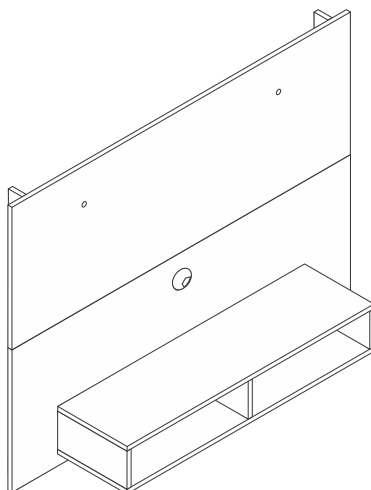

## Antes de começar Before starting Antes de comenzar

Antes de começar a montagem prepare o ambiente, deixando-o completamente limpo e com bom espaço para iniciar o trabalho.

Prepare the room before starting the assembly, leaving it completely clean and the area in good condition to start the work.

Antes de comenzar el montaje preparar el ambiente, dejándolo completamente limpio y con bueno espacio para comenzar el trabajo.

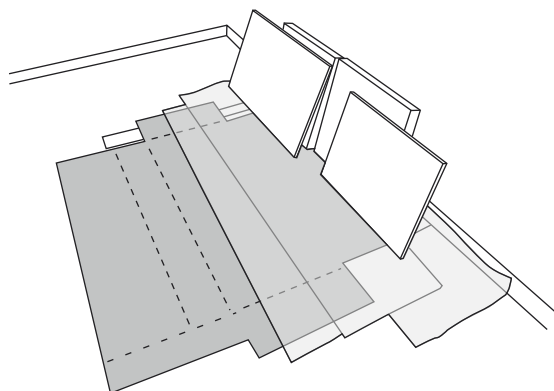

Utilize o papelão da própria embalagem para separar e apoiar as peças retiradas das caixas.

Use the cardboard of the packaging to separate and support the parts removed from the boxes.

Utilice el cartón de la embalaje para separar y apoyar las piezas desmontadas de las cajas.



Forre a área de montagem com um cobertor ou tapete. Assim, você evita avarias nas peças durante o processo de montagem.

Cover the assembly area with a blanket or carpet to avoid damaging the parts during the assembly process.

Cubrir la zona de ensamble con una manta o alfombra. De este modo, se evitan daños en las piezas durante el proceso de montaje.



## Evite acidentes Avoid accidents Prevenir accidentes

Solicitamos observar atentamente as orientações de montagem como: fixação do produto na parede, colocação de cola em locais específicos necessários, o peso suportado pelo produto, etc...

You are requested to carefully observe the assembly instructions regarding: fixing of products to the wall, adding glue where indicated, product weight limit, etc.

Pedimos que lea atentamente las instrucciones, principalmente las informaciones de fijación del producto en la pared, colocación de pegamento en local específico y necesario, el peso soportado por el producto etc...

Não escale ou se apoie no móvel.

Do not climb or lean on the furniture.

No se suba ni se apoye en el mueble.

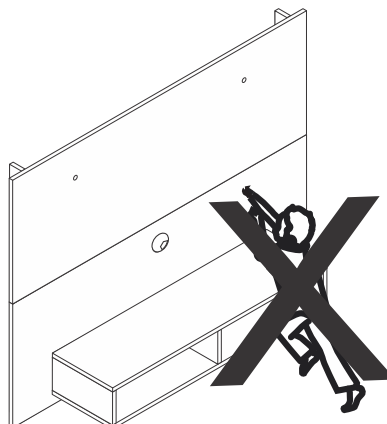

Dimensões e ferramentas  
Dimensions and tools  
Dimensiones y herramientas

Dimensões:

L: 1220 A: 890 P: 315 mm

Dimensions:

W: 48.03 H: 35.03 D: 12.40 inches

Dimensiones:

L: 1220 A: 890 P: 315 mm

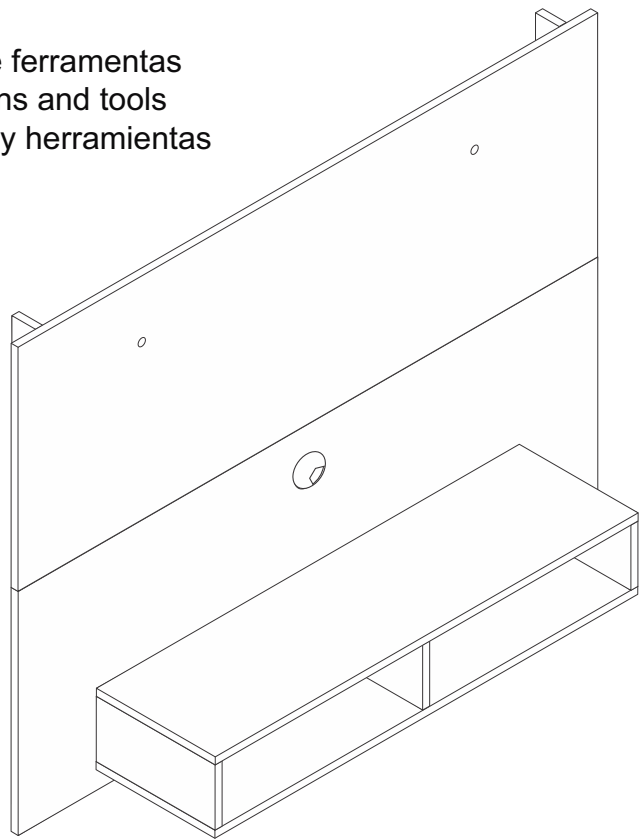

Limpeza  
Cleaning  
Limpieza

Pano levemente umedecido com água, seguido de pano seco, não utilizar produtos químico ou abrasivos.  
You can clean the product with slightly dampened cloth followed by a dry cloth. Do not use chemicals or abrasives.  
Solamente utilizar un paño húmedo y después un paño seco, no utilice productos químicos o abrasivos.

Todas as peças do móvel foram marcadas com um número. Antes de começar a montagem, identifique as peças numeradas em relação às instruções de montagem. Uma vez concluída a montagem, os números podem ser facilmente removidos com um pano ligeiramente embebido em álcool. Use álcool apenas para remover números das peças.

All the furniture parts have been marked with a number. Before you start assembling, please identify the numbered parts in relation to the assembly instructions. Once assembly is completed, the numbers can be easily removed with a cloth slightly damped in alcohol. Use alcohol only to remove part numbers.

Todos las piezas del mueble fueron marcadas con un número. Antes de empezar el montaje, identifique las piezas numeradas en relación con las instrucciones de montaje. Una vez que se completa el armado, los números se pueden quitar fácilmente con un paño ligeramente empapado en alcohol. Use alcohol solo para eliminar números de las piezas.

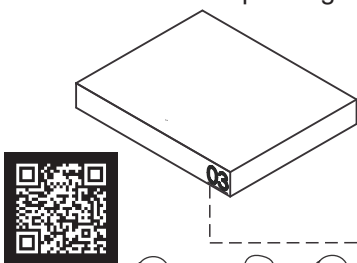

**UTILIZE ALCOOL APENAS PARA REMOVER O NUMERO DAS PEÇAS**  
**USE ALCOHOL ONLY TO REMOVE PART NUMBERS**  
**UTILICE ALCOHOL SOLAMENTE PARA ELIMINAR EL NUMERO DE LAS PIEZAS**

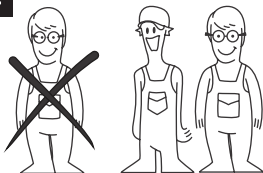

Para facilitar a montagem, utilize uma parafusadeira elétrica.  
To speed assembly, use an electronic screwdriver.  
Para facilitar el armado, utilice un destornillador eléctrico.

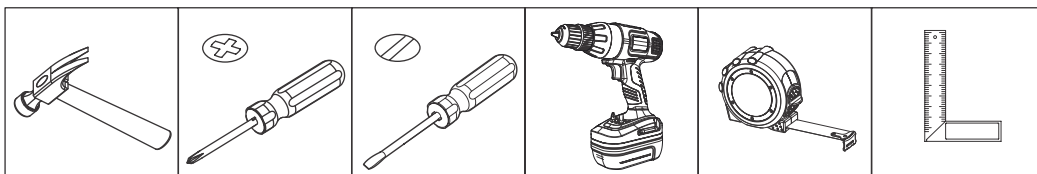

# COD BR: RP 06

PEÇA	DESCRIÇÃO	QUANT.
001	APOIO	2
002	BASE	1
003	DIVISÓRIA	1
004	LATERAL DIREITA	1
005	LATERAL ESQUERDA	1
006	PAINEL INFERIOR	1
007	PAINEL SUPERIOR	1
008	TAMPO	1
009	TRAVESSA LATERAL	2
011	UNIÃO PAINEL	2

PART	DESCRIPTION	QTY
001	SUPPORT	2
002	BASE	1
003	PARTITION	1
004	RIGHT SIDE	1
005	LEFT SIDE	1
006	BOTTOM PANEL	1
007	TOP PANEL	1
008	TOP	1
009	SIDE TRAVERSE	2
011	UNION PANEL	2

PIEZA	DESCRIPCIÓN	CANTIDAD
001	APOYO	2
002	BASE	1
003	PARTICIÓN	1
004	LATERAL DERECHA	1
005	LATERAL IZQUIERDA	1
006	PAINEL INFERIOR	1
007	PAINEL SUPERIOR	1
008	TAPA	1
009	TRAVESAÑO LATERAL	2
011	UNIÓN PANEL	2

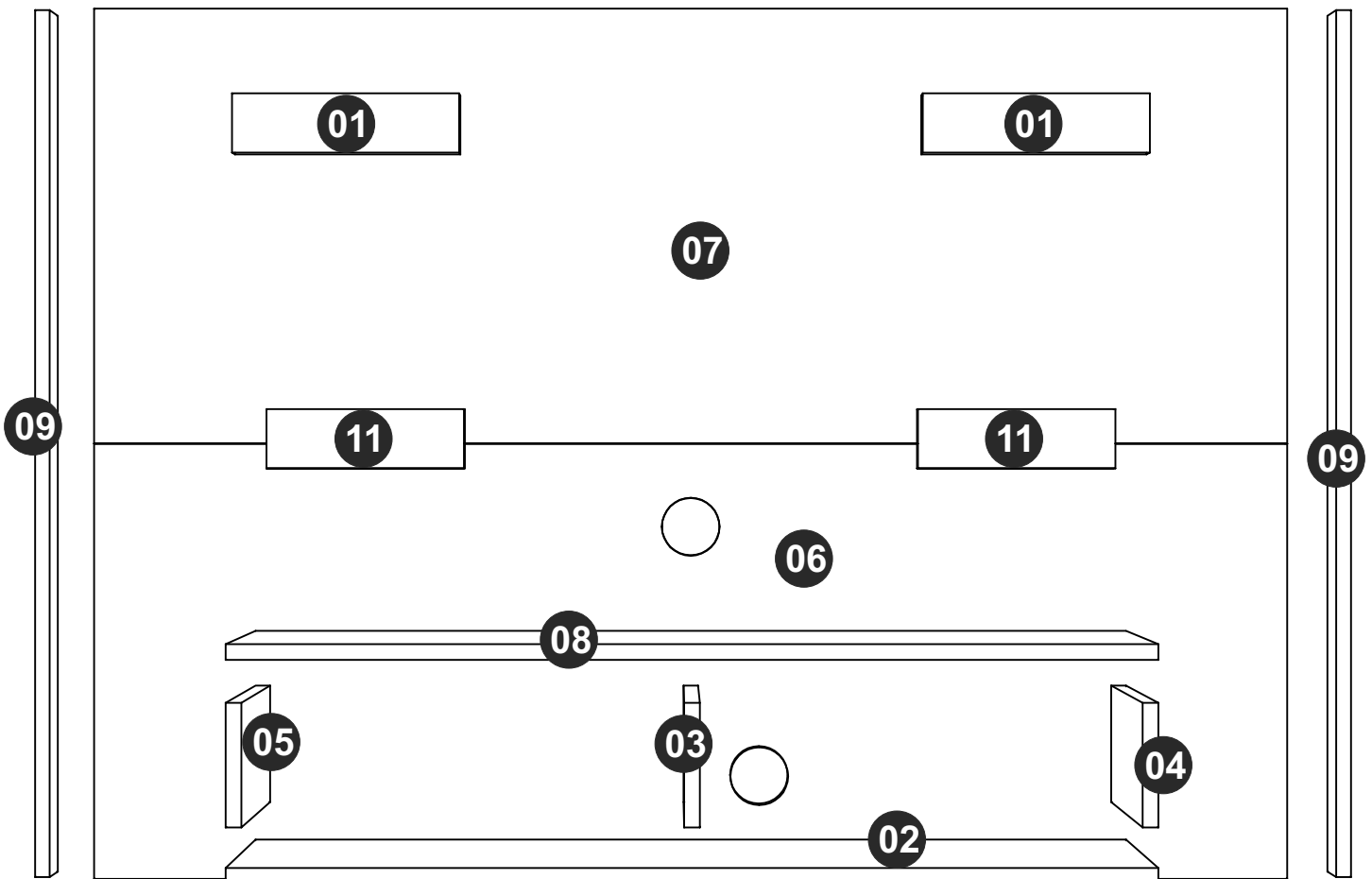



EF 000033x 10  
8x30



EF 000248 X 32  
3,5X14 CP



EF 000016 X 4



EF 000132 x 14  
4X50 CC

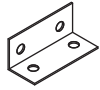

EF 000061 X 8



PASSA - FIO X 2  
PASS - WIRE x 2  
PASA - CABLE x 2

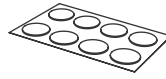

TAPA FUROS x 12  
STICKER x 12  
TAPAS HUECOS x 12



EF 000521 x 4  
5,5X50 CP



GIZ x 1  
CHALK x 1  
TIZA x 1

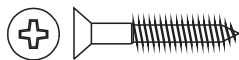

EF 000134 X 8  
4,5X25 CC



EF 000553 x 2



EF 000531 x 2  
1/4 X 2"



EF 000001 X 2

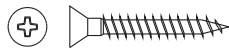

EF 000136 X 4  
4,5X35 CC



EF 000094 X 6



EF 000216 X 6



TAMPA PLÁSTICA x 02  
PLASTIC COVER x 02  
TAPA PLASTICA x 02



EF 000533 x 2



EF 000534 x 2

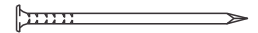

EF 000168 X 2  
10x10 C/C



PÉS REDONDOS x 2  
ROUND FEET x 2  
PIES REDONDOS x 2

Utilize para medir as ferragens.

Utilice para medir el herraje.

Use for measuring the hardware.

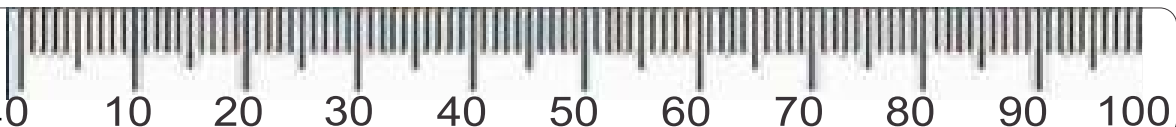

**Garantia (exclusivo para o Brasil/exclusivo de Brasil/exclusive to Brazil):**

A garantia dos produtos fabricados pela BRV Móveis, abrange eventuais defeitos-vícios de fabricação, no prazo estabelecido pelo código de Defesa do Consumidor, em seu artigo 26.II. o qual prevê a garantia de 90 (noventa) dias.

**A** = 18 KG - 39.70 LB

**B** = 4 KG - 8.81 LB

**C** = 1 KG - 2.20 LB

48"

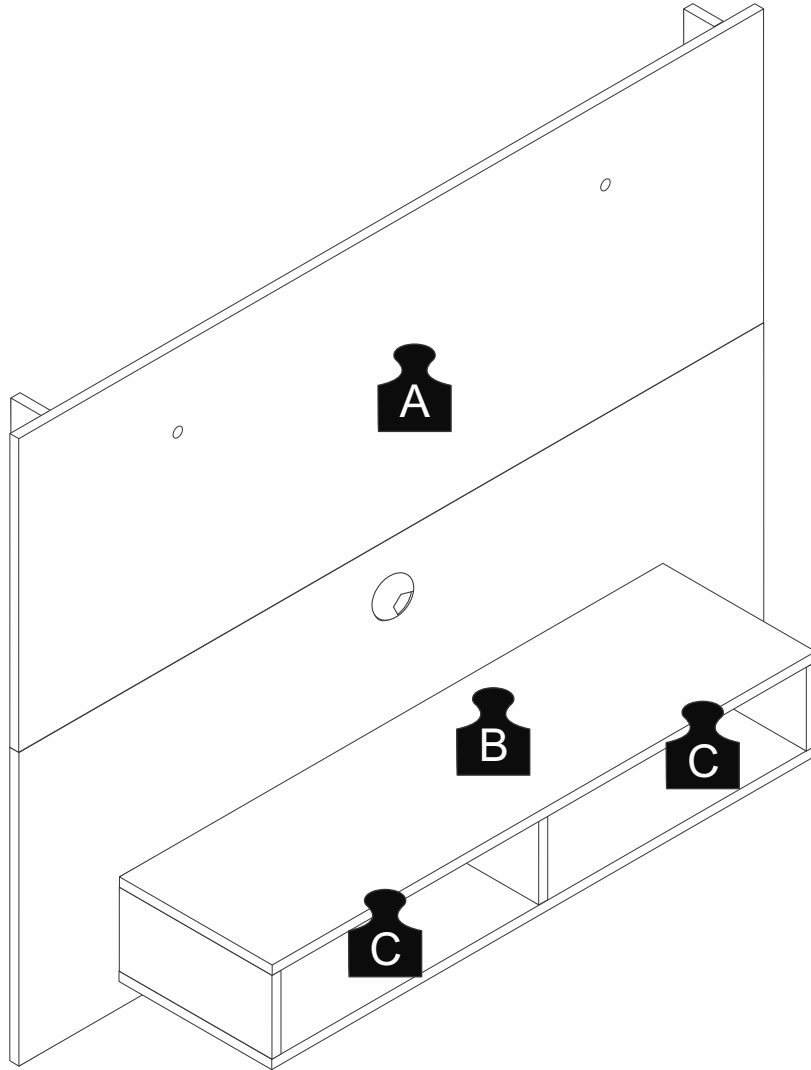

### PASSO 1 / STEP 1 / PASO 1

Insira a ferragem EF 000094 na peça 08.  
Insert hardware EF 000094 into piece 08.  
Añade el herraje EF 000094 en la pieza 08.

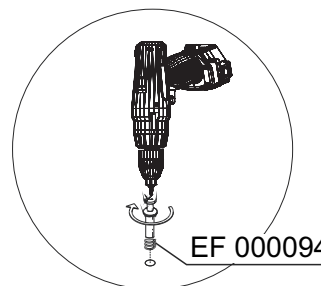
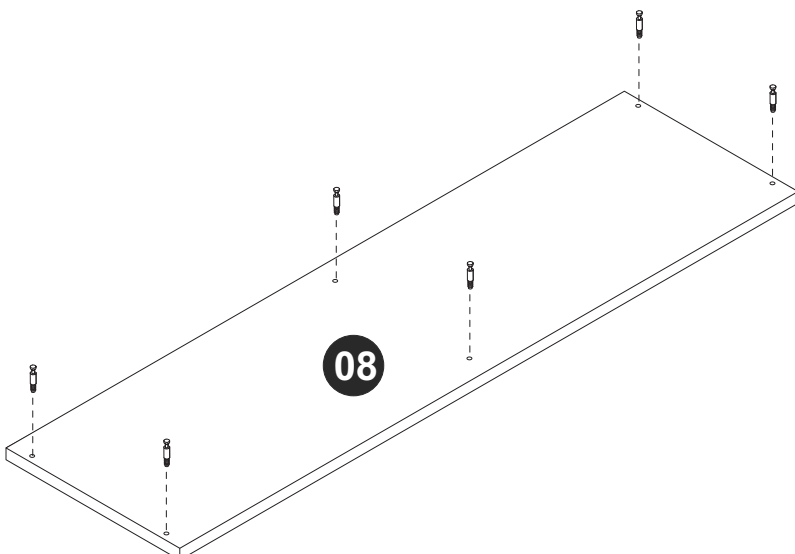



## PASSO 2 / STEP 2 / PASO 2

Insira a ferragem EF 000033 nas peças 03, 04 e 05.  
Insert hardware EF 000033 into pieces 03, 04 and 05.  
Añade el herraje EF 000033 en las piezas 03, 04 y 05.

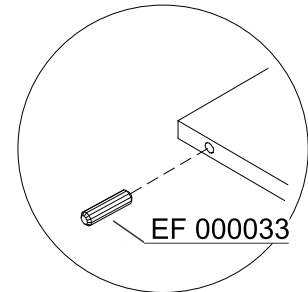
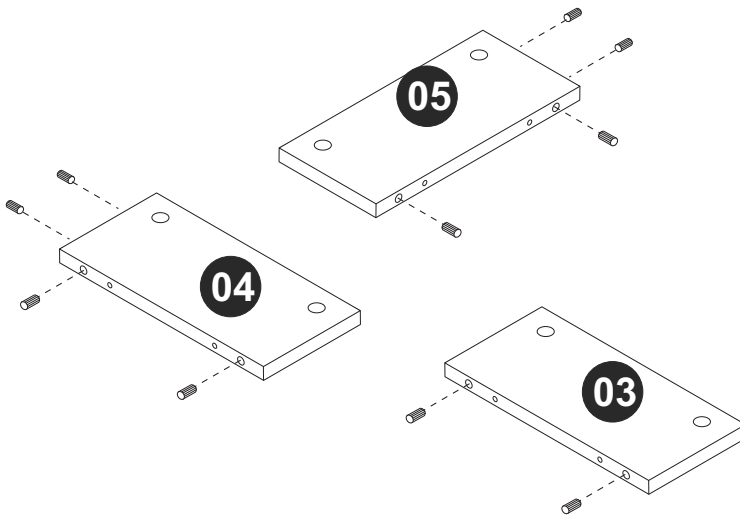

## PASSO 3 / STEP 3 / PASO 3

Insira o passa-fio na peça 06.  
Insert the pass-wire into piece 06.  
Añade el pasa-cable en la pieza 06.

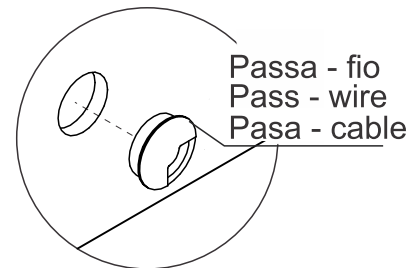
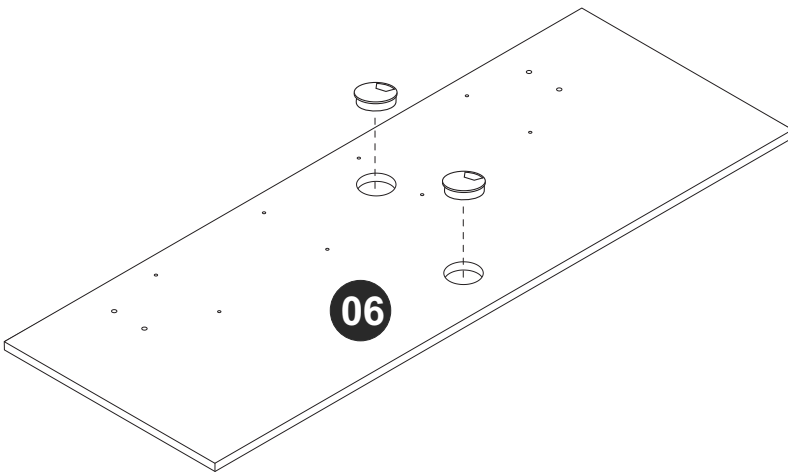

## PASSO 4 / STEP 4/ PASO 4

Conecte as peças 03, 04, 05 e 08, insira a ferragem EF 000216 e gire para apertar. Fixe a peça 02 utilizando ferragem EF 000132.  
Connect pieces 03, 04, 05 and 08, insert hardware EF 000216 and turn to tighten. Fix piece 02 using hardware EF 000132.  
Junte las piezas 03, 04, 05 y 08, añade el herraje EF 000216 y gire para apretar. Fije la pieza 02 utilizando el herraje EF 000132.

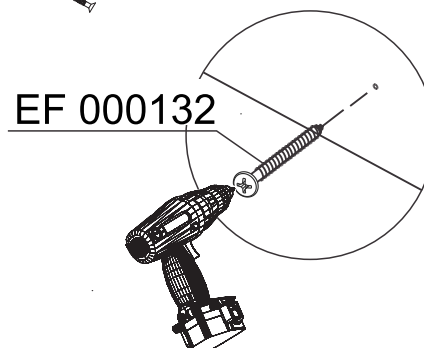
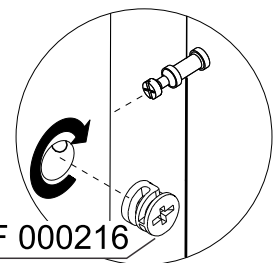
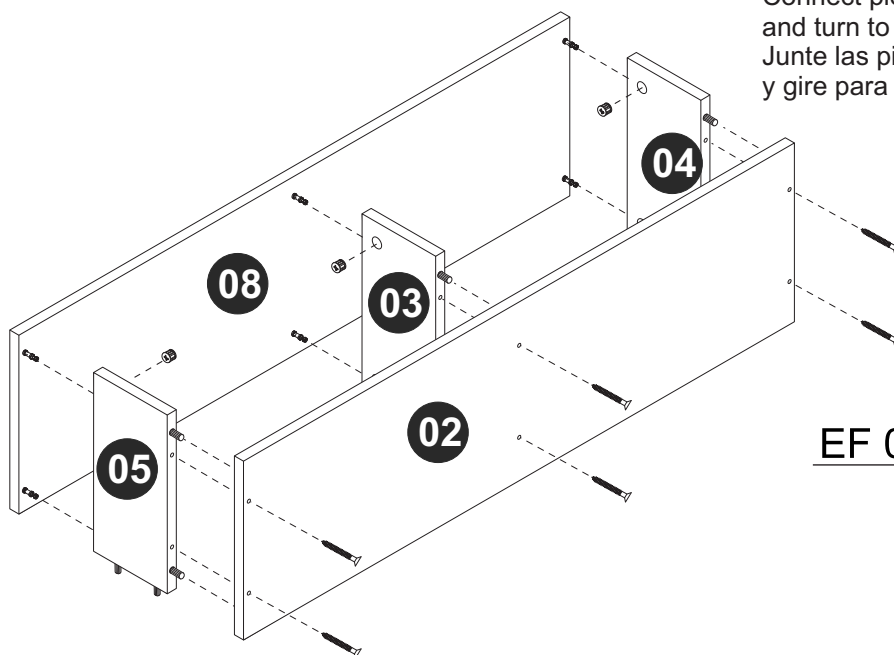

### PASSO 5 / STEP 5 / PASO 5

Fixe as peças 11 conectando as peças 06 e 07 utilizando a ferragem EF 000134. Fixe as peças 09 utilizando as ferragens EF 000061 e EF 000248. Attach pieces 11 connecting the pieces 06 and 07 using hardware EF 000134. Attach pieces 09 using hardware EF 000061 and EF 000248. Fije las piezas 11 conectando las piezas 06 y 07 utilizando el herraje EF 000134. Fije las piezas 09 utilizando los herrajes EF 000061 y EF 000248.

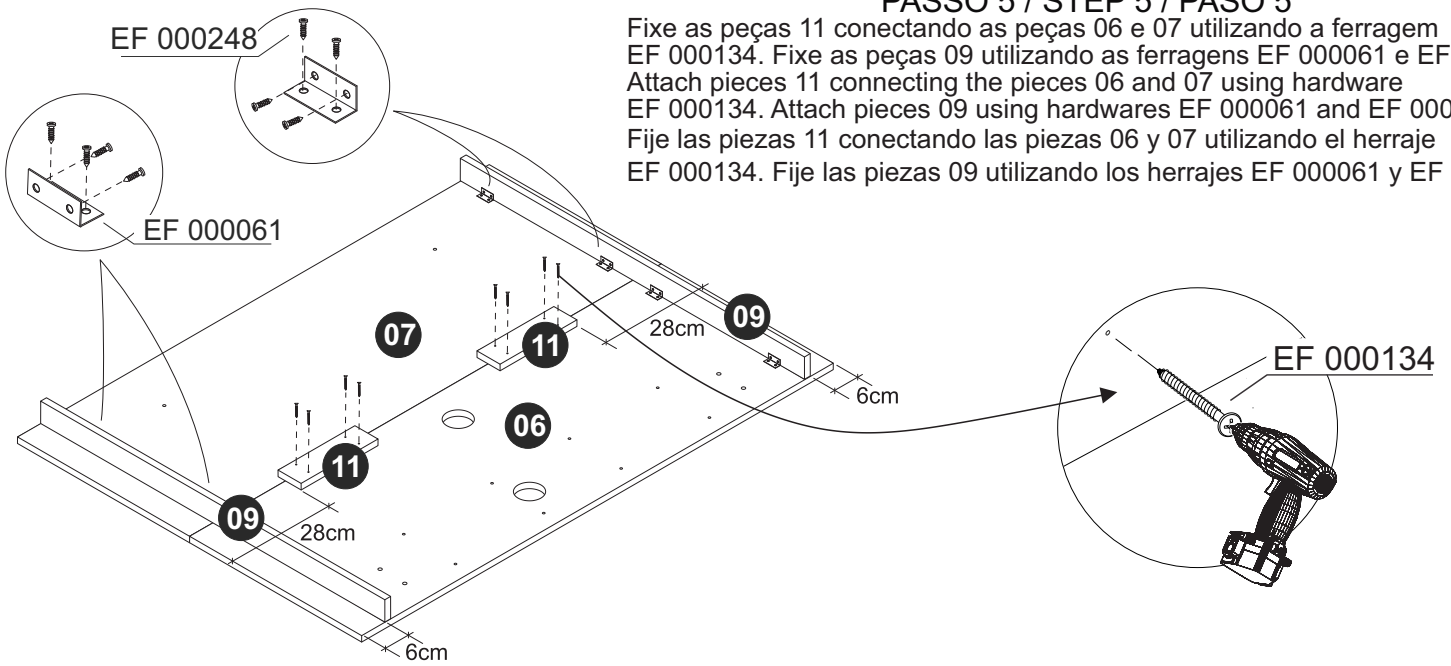

### PASSO 6 / STEP 6 / PASO 6

Fixe as peças 01 e a ferragem EF 000533 utilizando as ferragens EF 000531, EF 000001 e EF 000553. Attach pieces 01 and the hardware EF 000533 using hardware EF 000531, EF 000001 and EF 000553. Fije las piezas 01 y el herraje EF 000533 utilizando los herrajes EF 000531, EF 000001 y EF 000553.

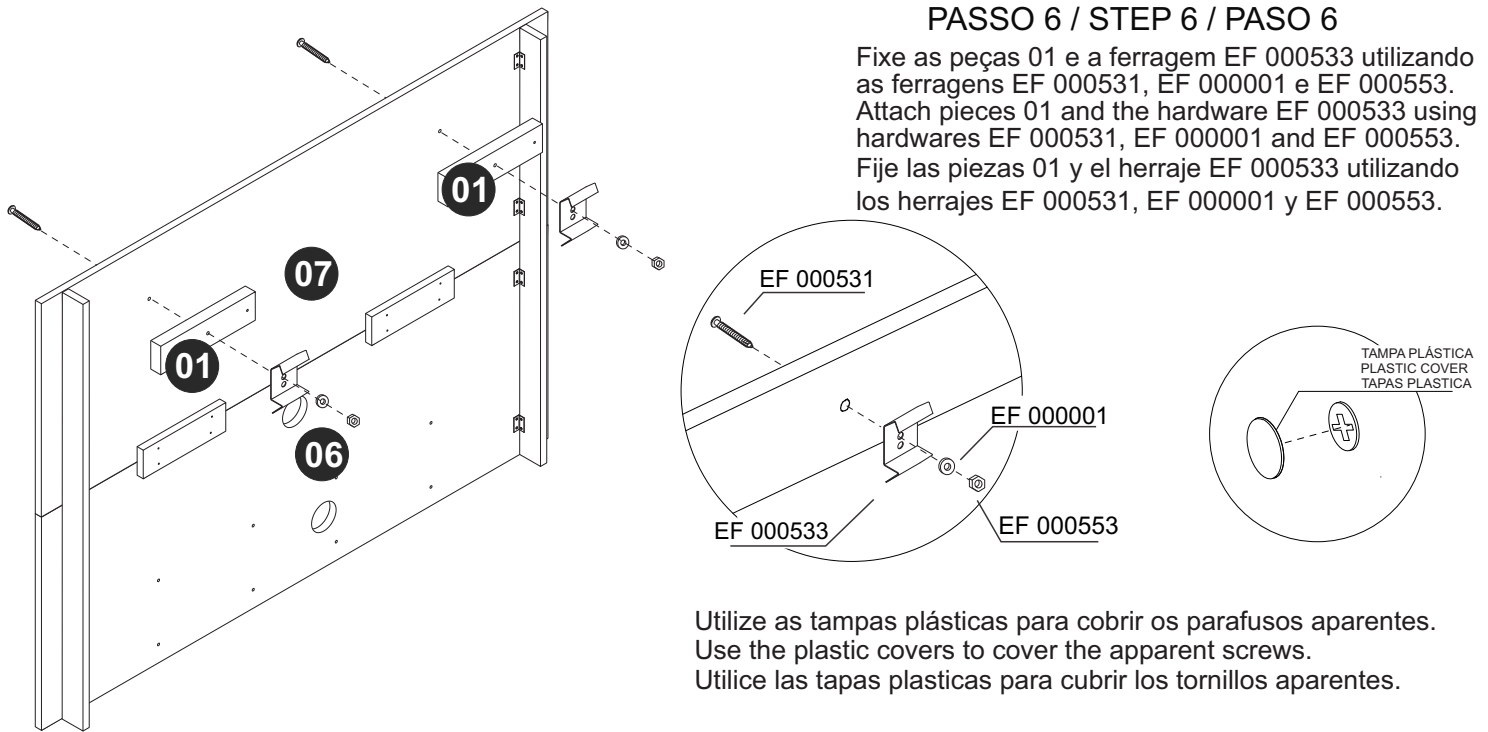

Utilize as tampas plásticas para cobrir os parafusos aparentes.  
Use the plastic covers to cover the apparent screws.  
Utilice las tapas plasticas para cubrir los tornillos aparentes.

### PASSO 7 / STEP 7 / PASO 7

Fixe as ferragens EF 000136 nas peças 01 e fixe os pés usando a ferragem EF 000168. Attach the hardware EF 000136 into pieces 01 and fix the feet using hardware EF 000168. Fije los herrajes EF 000136 en las piezas 01 y fije los pies utilizando el herraje EF 000168.

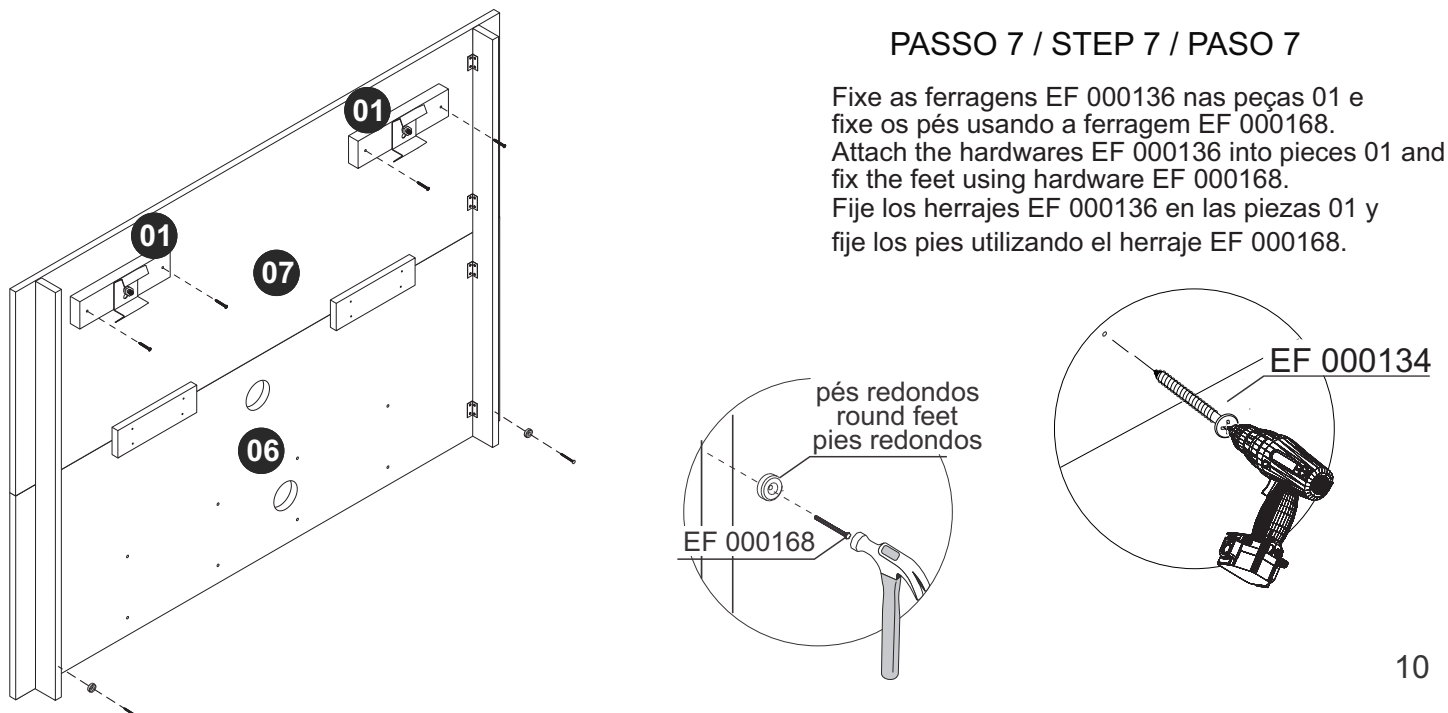

### PASSO 8 / STEP 8 / PASO 8

Conecte a parte montada no passo anterior à parte montada no passo 4 utilizando a ferragem EF 000132.  
Connect the part assembled in the previous step to the part assembled in the step 4 using hardware EF 000132.  
Junte la parte ensamblada en el paso anterior a la parte ensamblada en el paso 4 utilizando el herraje EF 000132.

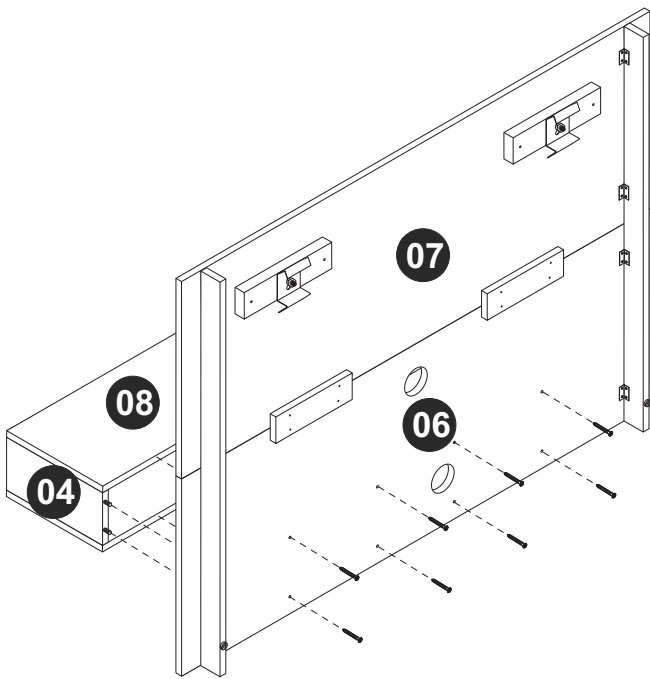

### PASSO 9 / STEP 9 / PASO 9

Perfure a parede e insira a ferragem EF 000016. Fixe a ferragem EF 000534 na parede utilizando a ferragem EF 000521 e conecte o painel na parede.  
Drill the wall and insert hardware EF 000016. Attach the hardware EF 000534 to the wall using hardware EF 000521 and connect the panel to the wall.  
Perfore la pared y añade el herraje EF 000016. Fije el herraje EF 000534 en la pared utilizando el herraje EF 000527, añade el panel en la pared.

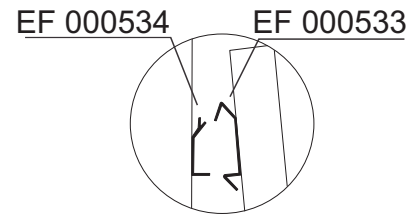
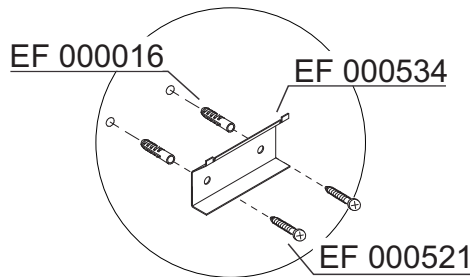
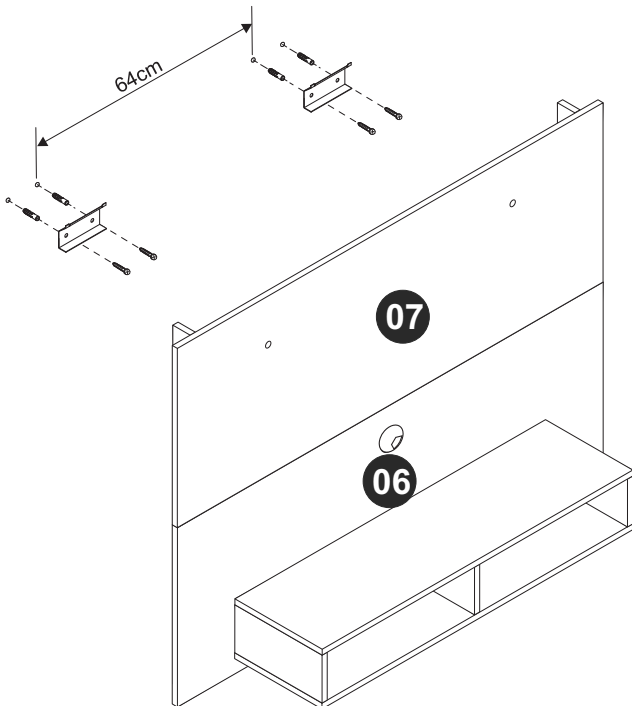

Encaixe do painel na parede  
Encaje del panel en la pared  
Wall panel insert

### PASSO 10 / STEP 10 / PASO 10

Use o giz para dar o acabamento final ao produto.  
Use the chalk to give the final finish on the product.  
Utilice la tiza para dar el acabado final al producto.  
Utilize o tapa furos para cobrir os parafusos aparentes.  
Use the sticker to cover the apparent screws.  
Utilice los tapa huecos para cubrir los tornillos aparentes.

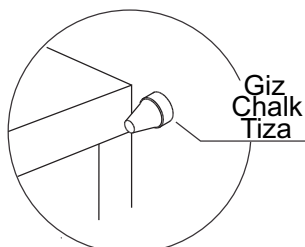
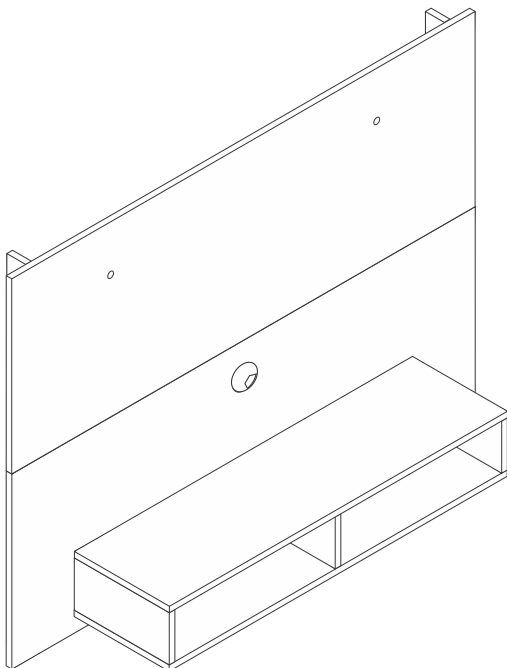

Giz  
Chalk  
Tiza

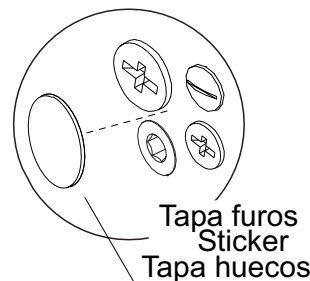

Tapa furos  
Sticker  
Tapa huecos

