



**MANUAL DE MONTAGEM
ASSEMBLY INSTRUCTIONS
INSTRUCCIONES DE MONTAJE**

COD BR: BBN 12

Sumário Summary Resumen

Introdução Introduction Introducción	3
Antes de começar Before starting Antes de comenzar	4
Evite acidentes Avoid accidents Evitar accidentes	4
Dimensões e ferramentas Dimensions and tools Dimensiones y herramientas	5
Identificação das peças Identifying parts Identificación de las piezas	6
Acessórios incluídos na caixa Hardware included in box Accesorios incluidos en la caja	7
Montagem do móvel Furniture assembly Montaje del mueble	8

Introdução Introduction Introducción

Leia atentamente este manual e siga os passos indicados para que o produto não perca a garantia e também para uma perfeita montagem.

Read this manual and follow the steps in order to keep the guarantee and also for the perfect fit.

Lea este manual y siga los pasos para que el producto no pierda la garantía y también para el ajuste perfecto.

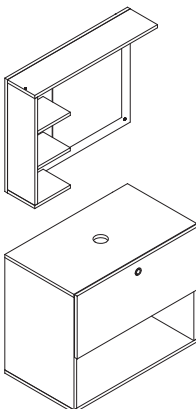

Antes de começar Before starting Antes de comenzar

Antes de começar a montagem prepare o ambiente, deixando-o completamente limpo e com bom espaço para iniciar o trabalho.

Prepare the room before starting the assembly, leaving it completely clean and the area in good condition to start the work.

Antes de comenzar el montaje preparar el ambiente, dejándolo completamente limpio y con bueno espacio para comenzar el trabajo.

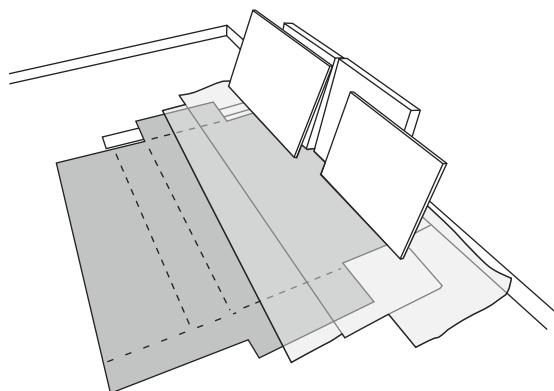

Utilize o papelão da própria embalagem para separar e apoiar as peças retiradas das caixas.

Use the cardboard of the packaging to separate and support the parts removed from the boxes.

Utilice el cartón de la embalaje para separar y apoyar las piezas desmontadas de las cajas.

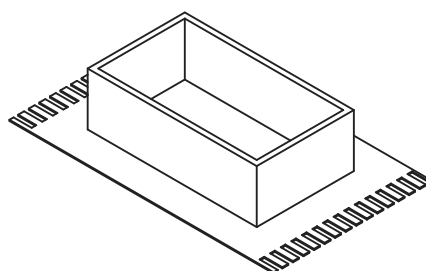

Forre a área de montagem com um cobertor ou tapete. Assim, você evita avarias nas peças durante o processo de montagem.

Cover the assembly area with a blanket or carpet to avoid damaging the parts during the assembly process.

Cubrir la zona de ensamble con una manta o alfombra. De este modo, se evitan daños en las piezas durante el proceso de montaje.



Evite acidentes Avoid accidents Prevenir accidentes

Solicitamos observar atentamente as orientações de montagem como: fixação do produto na parede, colocação de cola em locais específicos necessários, o peso suportado pelo produto, etc...

We request you to carefully observe the assembly instructions as: fixing the product on the wall, adding glue in needed and specific places, product weight limit, etc.

Pedimos que lea atentamente las instrucciones, principalmente las informaciones de fijación del producto en la pared, colocación de pegamento en local específico y necesario, el peso soportado por el producto etc...

Não escale ou se apoie no móvel.

Do not climb or lean on the furniture.

No se suba ni se apoye en el mueble.

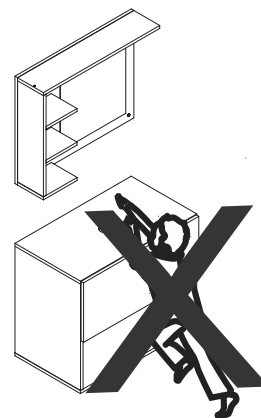

Dimensões e ferramentas
 Dimensions and tools
 Dimensiones y herramientas

Dimensões:
 L: 675 A: 539 P: 165 mm
 Dimensions:
 W: 26.57 H: 21.22 D: 6.49 inches
 Dimensiones:
 L: 675 A: 539 P: 165 mm

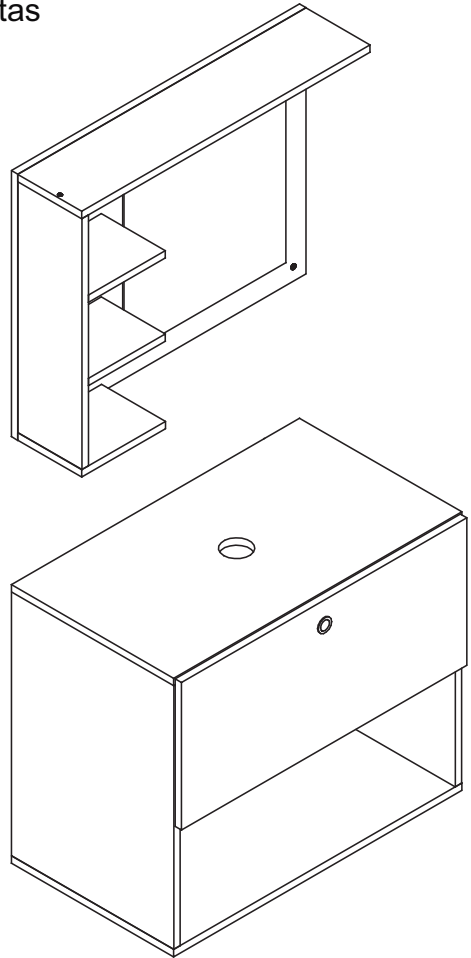

Dimensões:
 L: 675 A: 565 P: 395 mm
 Dimensions:
 W: 26.57 H: 22.24 D: 15.55 inches
 Dimensiones:
 L: 675 A: 565 P: 395 mm

Limpeza
 Cleanig
 Limpieza



Pano levemente umedecido com água, seguido de pano seco, não utilizar produtos químico ou abrasivos.
 Slightly dampened cloth and after a dry cloth, do not use chemicals or abrasives.
 Solamente utilizar un paño húmedo y después un paño seco, no utilice productos químicos o abrasivos.

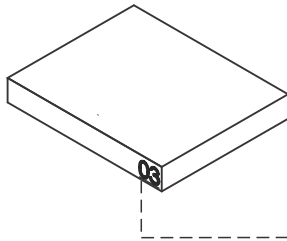

UTILIZE ALCOOL APENAS PARA REMOVER O NUMERO DAS PEÇAS
USE ALCOHOL ONLY TO REMOVE PART NUMBERS
UTILICE ALCOHOL SOLAMENTE PARA ELIMINAR EL NUMERO DE LAS PIEZAS

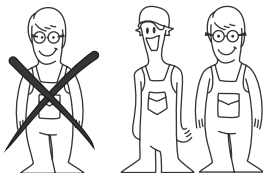

Para facilitar a montagem, utilize uma parafusadeira elétrica.
 To improve assembly, use an eletronic screwdriver.
 Para facilitar el armado, utilice un destornillador eléctrico.

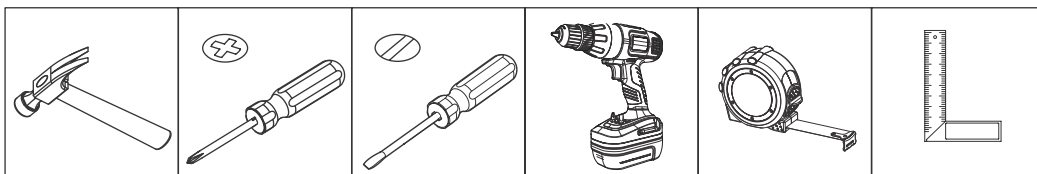

COD BR: BBN 12

PEÇA	DESCRIÇÃO	QUANT.	PART	DESCRIPTION	QTY	PIEZA	DESCRIPCIÓN	CANTIDAD
001	COSTA AÉREO	1	001	TOP CABINET BACK	1	001	REVÉS ARMARIO AÉREO	1
002	TAMPO AÉREO	1	002	TOP CABINET TOP	1	002	TAPA ARMARIO AÉREO	1
003	LATERAL AÉREO	1	003	CABINET SIDE	1	003	LATERAL ARMARIO	1
004	BASE AÉREO	1	004	TOP CABINET BASE	1	004	BASE ARMARIO AÉREO	1
005	PRATELEIRA AÉREO	2	005	TOP CABINET SHELF	2	005	REPISA ARMARIO AÉREO	2
006	BASE BALCÃO	1	006	CABINET BASE	1	006	BASE ARMARIO	1
007	TAMPO BALCÃO	1	007	CABINET TOP	1	007	TAPA ARMARIO	1
008	PRATELEIRA BALCÃO	1	008	CABINET SHELF	1	008	REPISA ARMARIO	1
009	LATERAL ESQUERDA BALCÃO	1	009	CABINET LEFT SIDE	1	009	LATERAL IZQUIERDA ARMARIO	1
010	LATERAL DIREITA BALCÃO	1	010	CABINET RIGHT SIDE	1	010	LATERAL DERECHA ARMARIO	1
011	FRENTE DE GAVETA	1	011	DRAWER FRONT	1	011	FRENTE DE CAJÓN	1
013	FUNDO DE GAVETA	1	013	DRAWER BOTTOM	1	013	FONDO DE CAJÓN	1

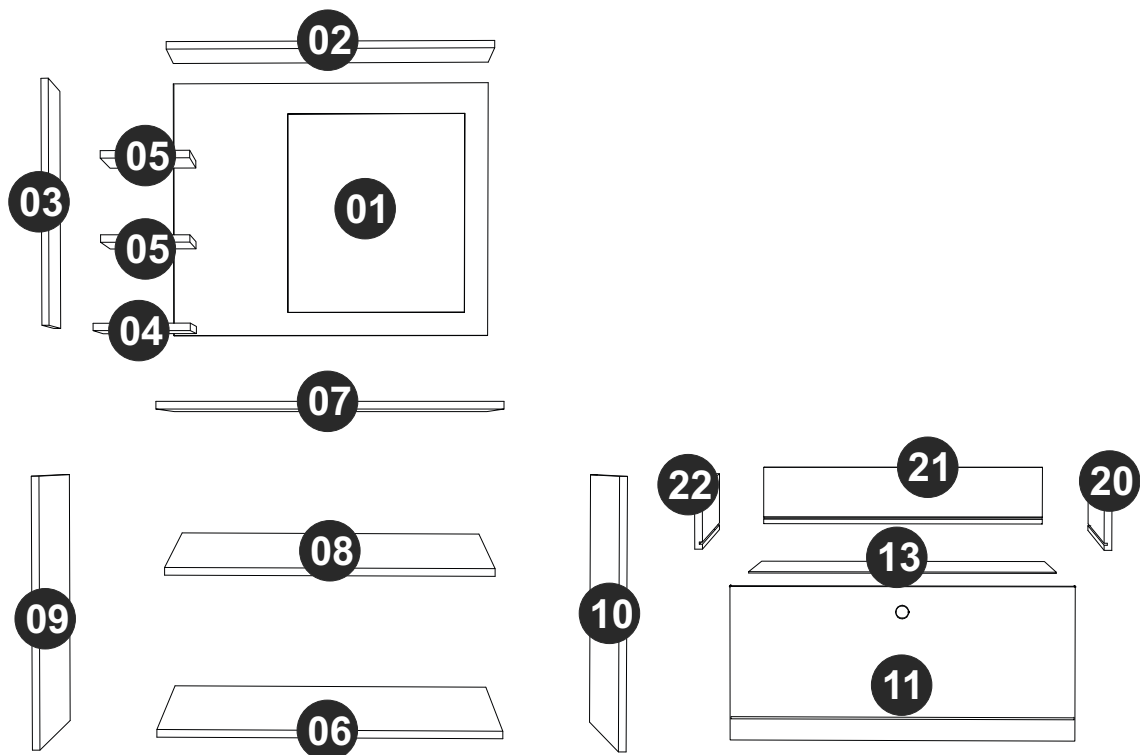

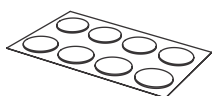

TAPA FUROS x 28
STICKER x 28
TAPAS PLÁSTICAS x 28



EF 000132 x 12
4X50 CC



EF 000106 x 20
3,5X14 CC



EF 000033 x 33
8x30



GIZ x 01
CHALK x 01
TIZA x 01



EF 000216 X 12



EF 000094 X 12



EF 000146 x 8
5X60 CC



CAPA PLASTICA x 4
PLASTIC COVER x 4
CAPA PLASTICA x 4



EF 000016 X 8



PUXADOR x 1
HANDLE x 1
MANIJA x 1

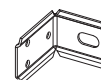

EF 000242 x 4



CORREDIÇAS x 2
DRWER TRACKS x 2
CORREDERAS x 2

Utilize para medir as ferragens.

Utilice para medir el herraje.

Use for measuring the hardware.

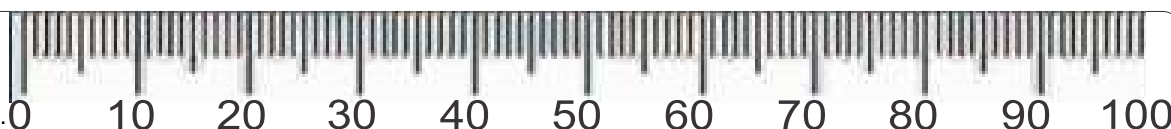

Garantia (exclusivo para o Brasil/exclusivo de Brasil/exclusive to Brazil):

A garantia dos produtos fabricados pela BRV Móveis, abrange eventuais defeitos-vícios de fabricação, no prazo estabelecido pelo código de Defesa do Consumidor, em seu artigo 26.II. o qual prevê a garantia de 90 (noventa) dias.

A = 9KG - 19.84LB

B = 2KG - 4.40LB

C = 1KG - 2.20LB

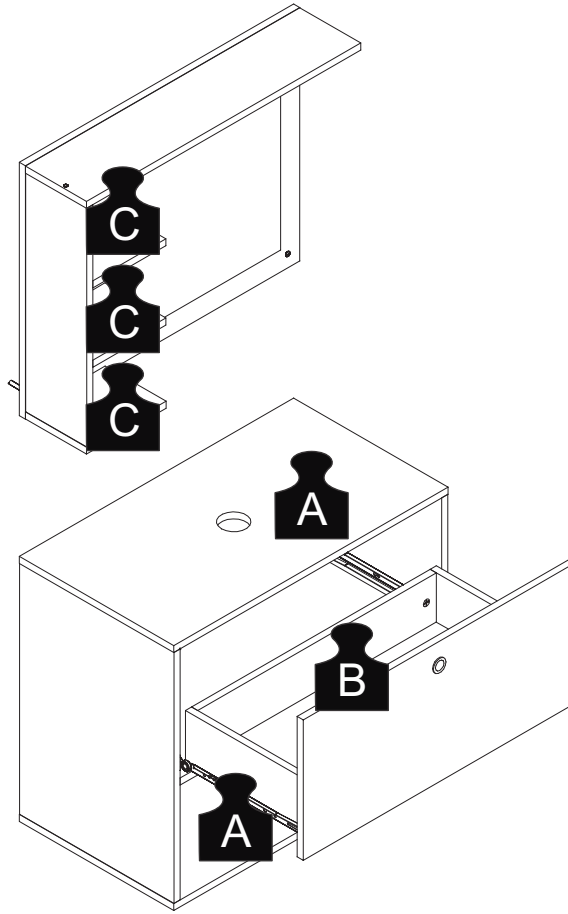

PASSO 1 / STEP 1 / PASO 1

Fixe a ferragem EF 000094 nas peças 07, 09, 10, 11, 20 e 22.
Fix hardware EF 000094 in pieces 07, 09, 10, 11, 20 and 22.
Fije el herraje EF 000094 en las piezas 07, 09, 10, 11, 20 y 22.

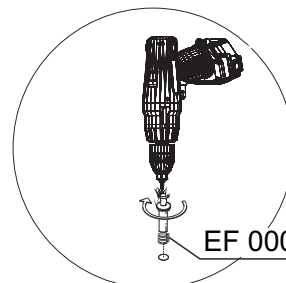
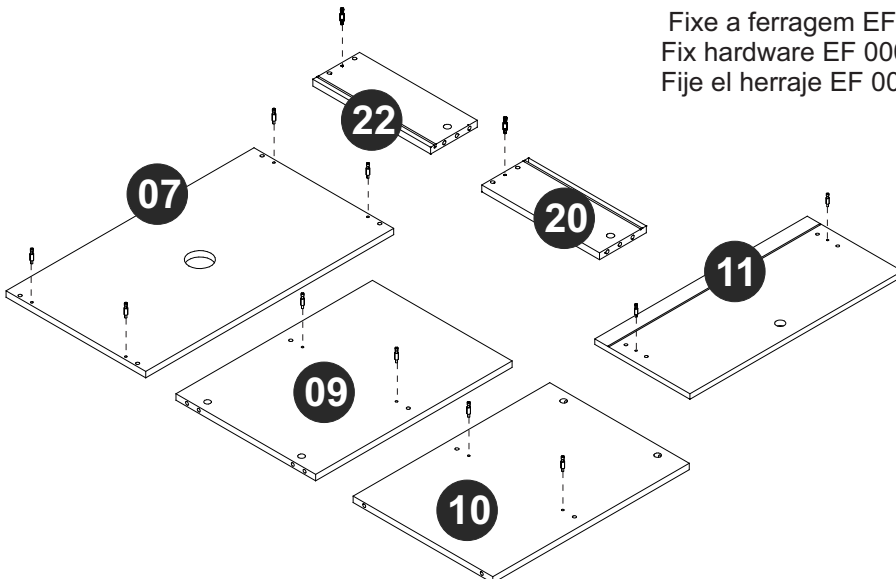

EF 000094



PASSO 2 / STEP 2 / PASO 2

Insira a ferragem EF 000033 nas peças 02, 03, 04 e 05.
Insert hardware EF 000033 in pieces 02, 03, 04 and 05.
Añade el herraje EF 000033 en las piezas 02, 03, 04 y 05.

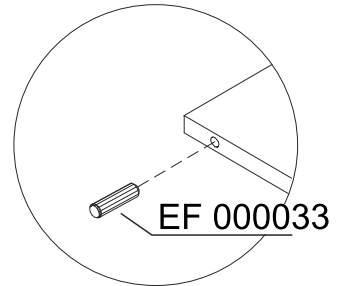
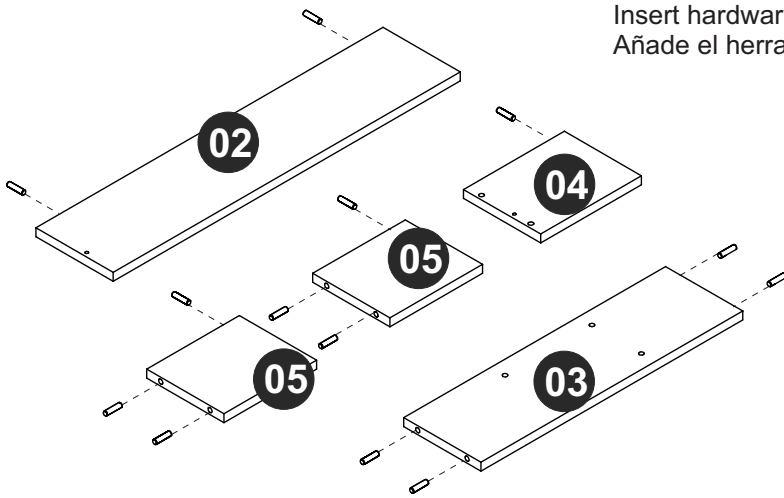

PASSO 3 / STEP 3 / PASO 3

Insira a ferragem EF 000033 nas peças 08, 09 e 10.
Insert hardware EF 000033 in pieces 08, 09 and 10.
Añade el herraje EF 000033 en las piezas 08, 09 y 10.

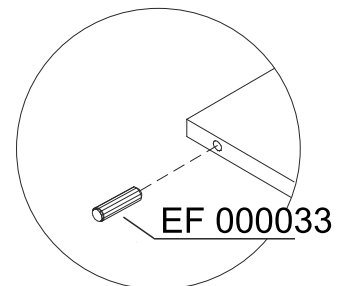
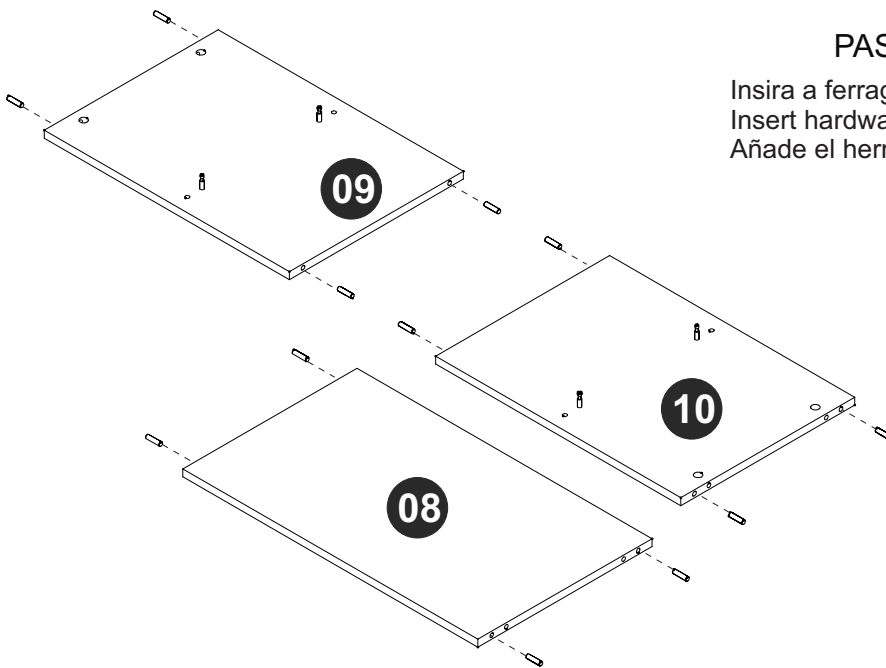

PASSO 4 / STEP 4 / PASO 4

Insira a ferragem EF 000033 nas peças 20, 21 e 22.
Insert hardware EF 000033 in pieces 20, 21 and 22.
Añade el herraje EF 000033 en las piezas 20, 21 y 22.

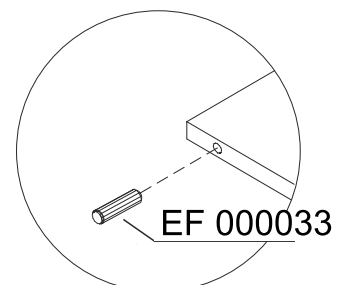
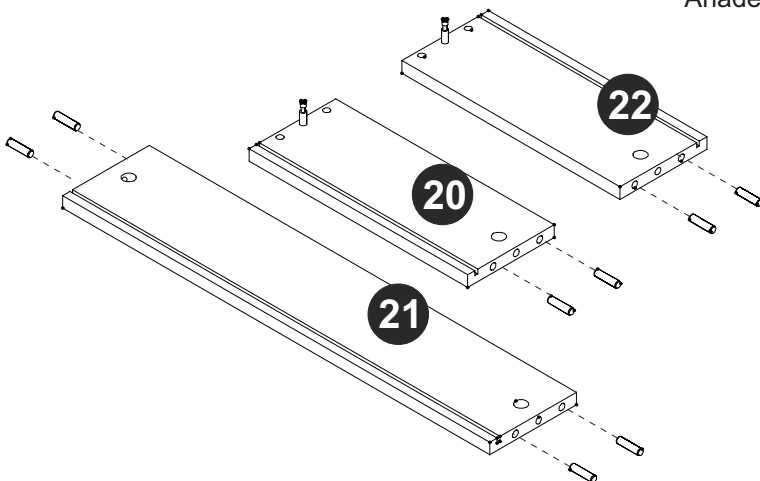

PASSO 5 / STEP 5 / PASO 5

Fixe a corrediça nas peças 09 e 10 utilizando a ferragem EF 000106.
Attach the drawer traks in pieces 09 and 10 using hardware EF 000106.
Fije las correderas en las piezas 09 y 10, utilizando el herraje EF 000106.

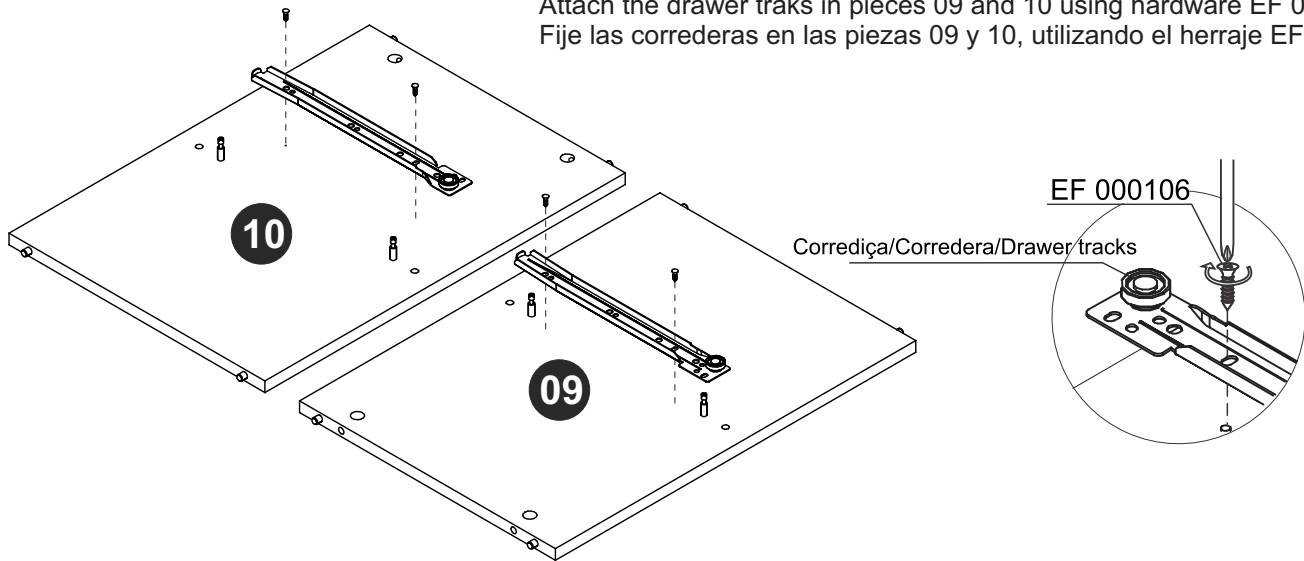

PASSO 6 / STEP 6 / PASO 6

Use a ferragem EF 000106 para fixar a ferragem EF 000242 nas peças 09 e 10.
Use hardware EF 000106 to attach hardware EF 000242 in pieces 09 and 10.
Utilice el herraje EF 000106 para fijar el herraje EF 000242 en las piezas 09 y 10.

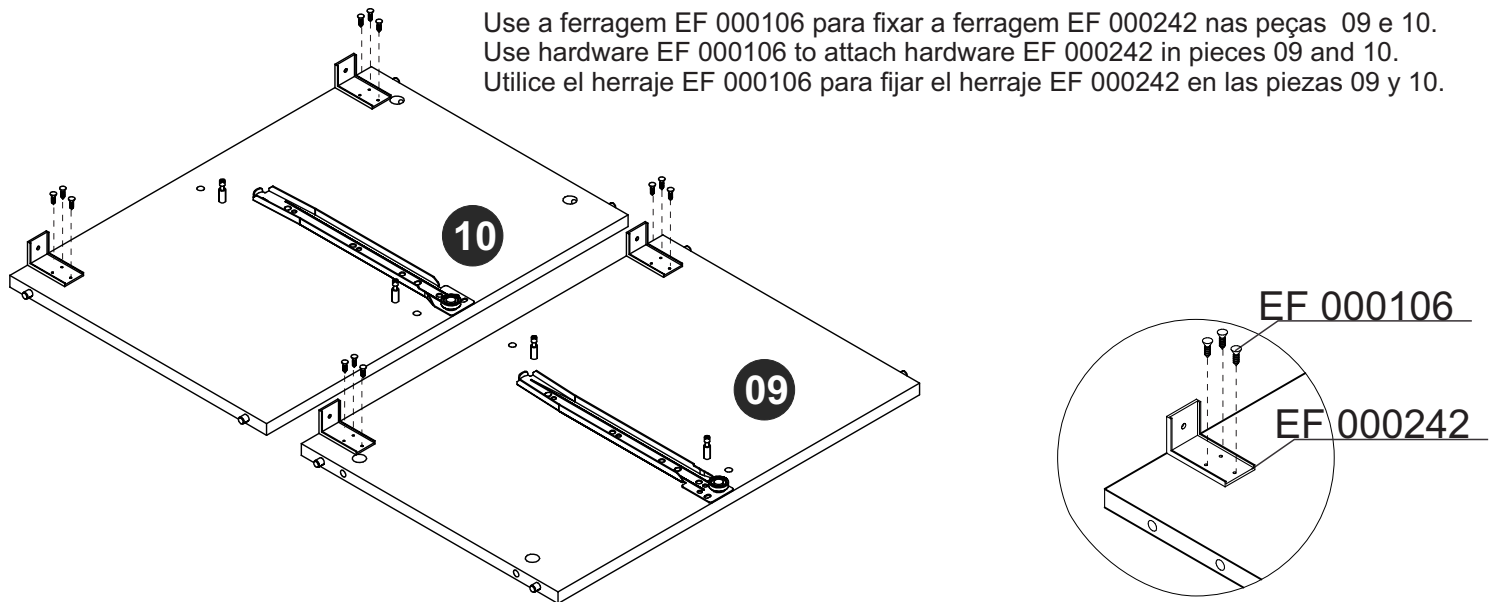

PASSO 7 / STEP 7 / PASO 7

Conecte as peças 08, 09 e 10, insira a ferragem EF 000216 e gire para apertar.
Connect pieces 08, 09 and 10, insert hardware EF 000216 and turn to tighten.
Junte las piezas 08, 09 y 10, añada el herraje EF 000216 y gire para apretar.

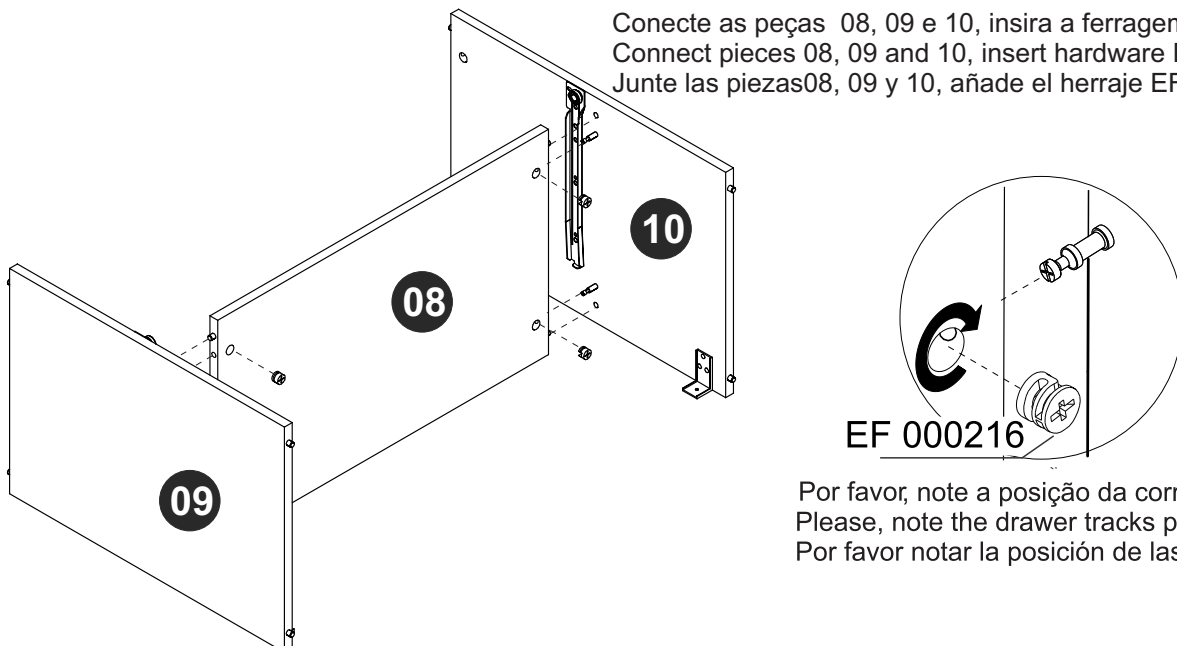

Por favor, note a posição da corrediça.
Please, note the drawer tracks position.
Por favor notar la posición de las correderas.

PASSO 8 / STEP 8 / PASO 8

Conecte a peça 07, insira a ferragem EF 000216 e gire para apertar.
Connect piece 07, insert hardware EF 000216 and turn to tighten.
Junte la pieza 07, añada el herraje EF 000216 y gire para apretar.

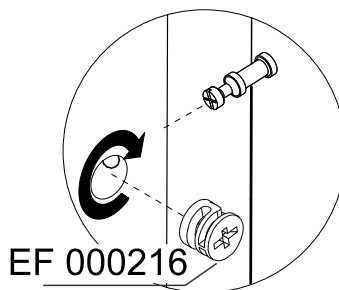
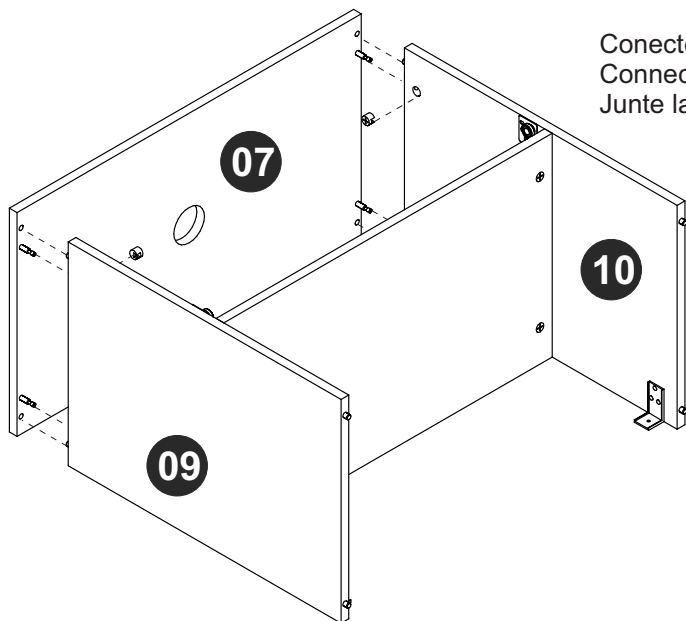

EF 000216

Por favor, note a posição da corrediça.
Please, note the drawer tracks position.
Por favor notar la posición de las correderas.

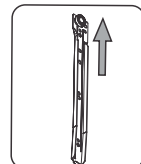

PASSO 9 / STEP 9 / PASO 9

Conecte a peça 06 utilizando ferragem EF 000132.
Connect piece 06 using hardware EF 000132.
Junte la pieza 06 utilizando el herraje EF 000132.

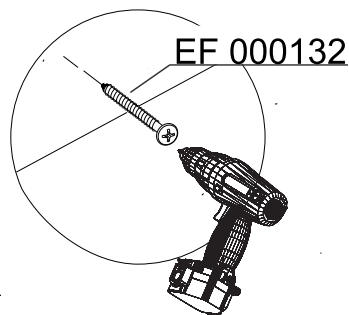
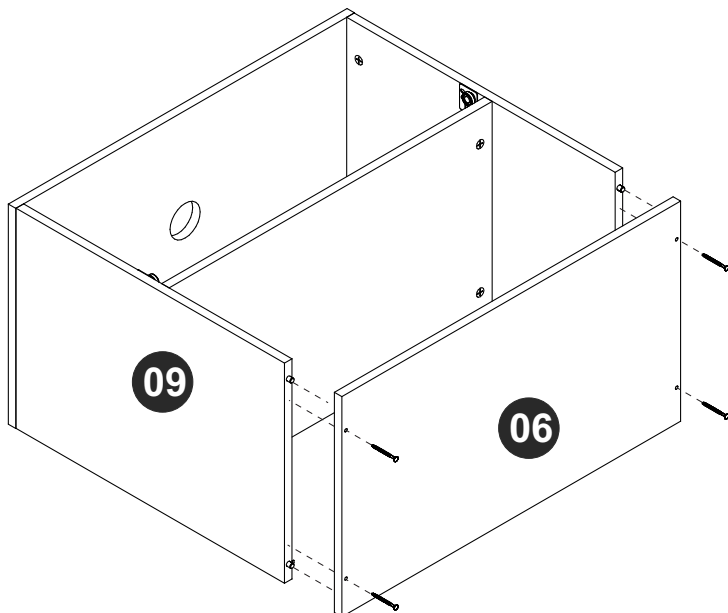

EF 000132

Por favor, note a posição da corrediça.
Please, note the drawer tracks position.
Por favor notar la posición de las correderas.

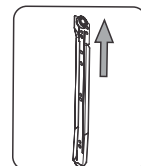

PASSO 10 / STEP 10 / PASO 10

Conecte as peças 20, 21 e 22, encaixando as ferragens EF 000094 e EF 000216 e gire a ferragem EF 000216 até apertar.
Connect pieces 20, 21 and 22 fitting hardwares EF 000216 and EF 000094, turn hardware EF 000216 to tighten.
Junte las piezas 20, 21 y 22, encajando los herrajes EF 000094 y EF 000216 y gire el herraje EF000216 hasta apretar.

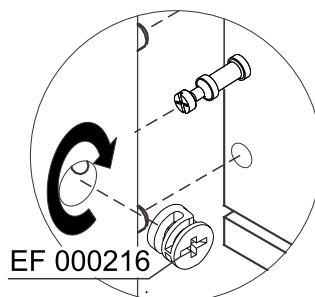
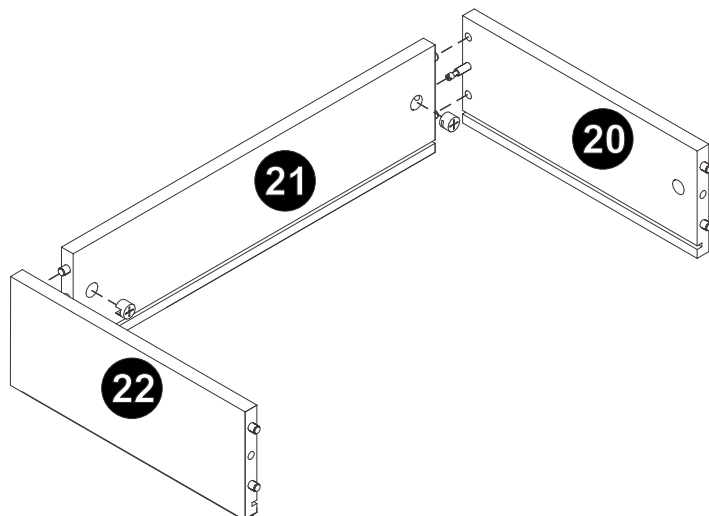

EF 000216



PASSO 11 / STEP 11/ PASO 11

Encaixe a peça 13 entre os espaços específicos nas peças 20 e 22.
Fix piece 13 at part assembled through the specific spaces in pieces 20 and 22.
Fije la pieza 13 entre los espacios especificos en las piezas 20 y 22.

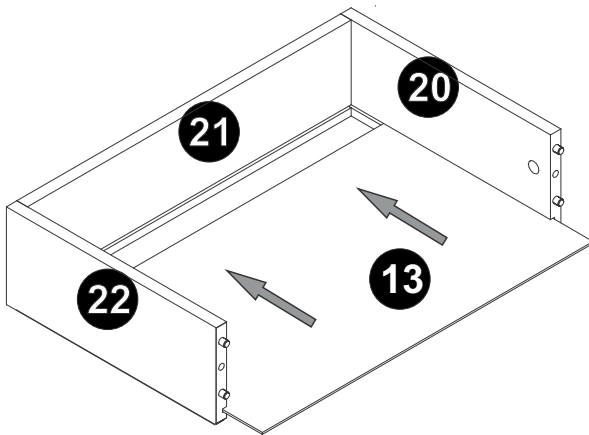

PASSO 12 / STEP 12 / PASO 12

Encaixe a peça 11, insira a ferragem EF 000216 e gire para apertar. Insira o puxador.
Fixe a peça 11, insert hardware EF 000216 and turn to tighten. Insert the handle.
Fije la pieza 11, añade el herraje EF 000216 y gire para apretar. Añade la manija.

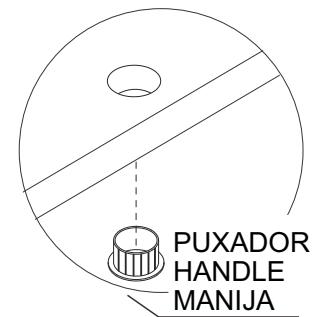
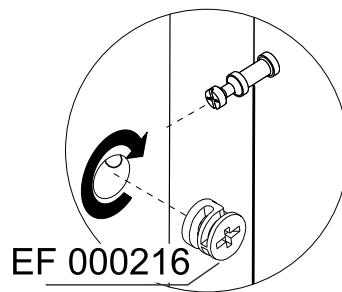
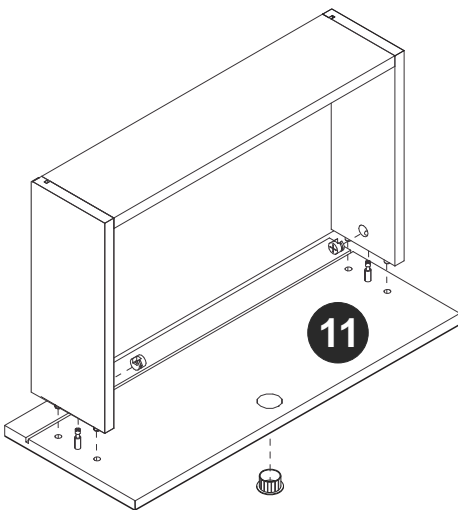

PASSO 13 / STEP 13 / PASO 13

Encaixeas peças 03 e 05.
Fit pieces 03 and 05.
Junte las piezas 03 y 05.

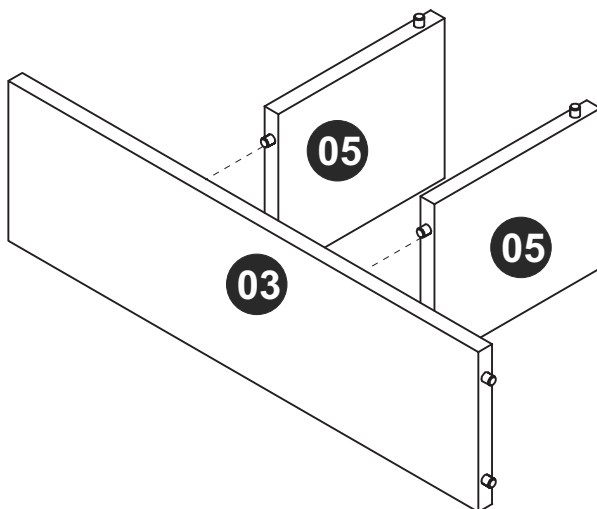

PASSO 14 / STEP 14/ PASO 14

Conecte as peças 02 e 04 utilizando ferragem EF 000132.
Connect pieces 02 and 04 using hardware EF 000132.
Junte las piezas 02 y 04 utilizando el herraje EF 000132.

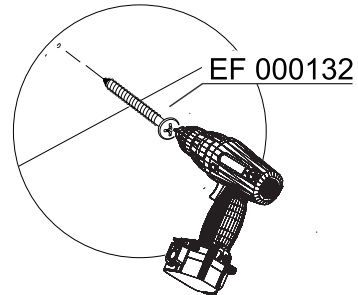
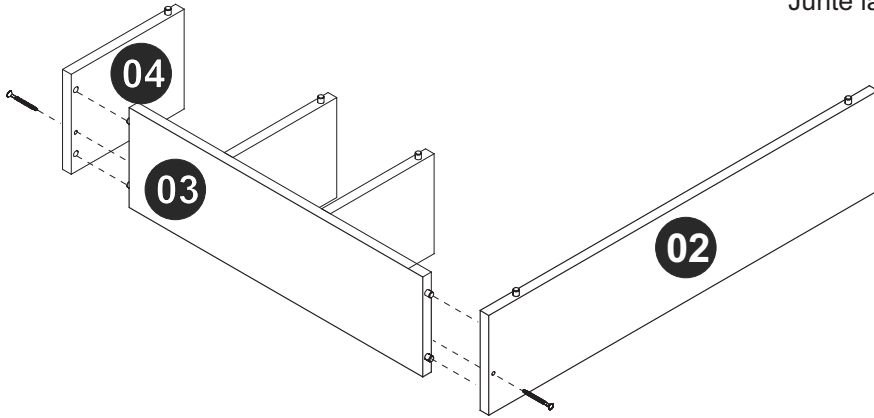

PASSO 15 / STEP 15 / PASO 15

Fixe peça 01 utilizando a ferragem EF 000132.
Fix the piece 01 using hardware EF 000132.
Fije la pieza 01 using el herraje EF 000132.

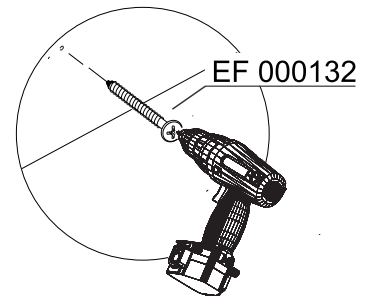
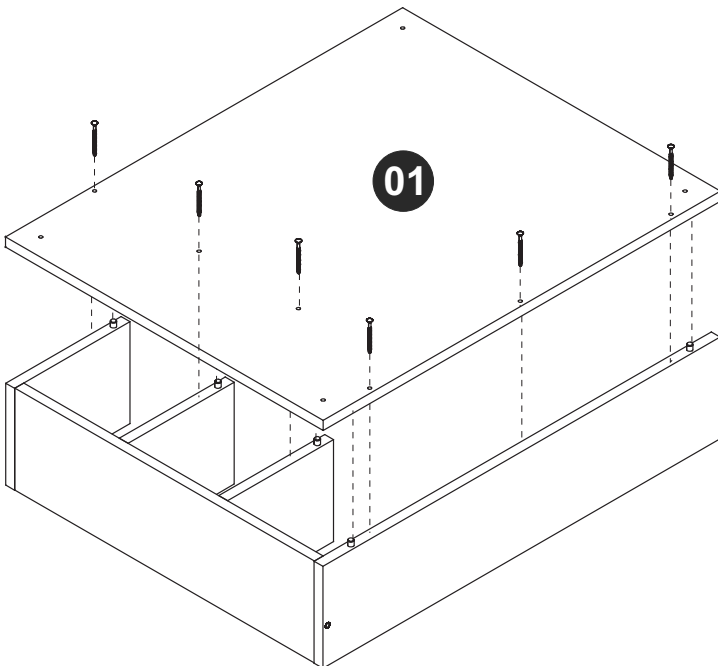

PASSO 16 / STEP 16 / PASO 16

Perfore a parede e insira a ferragem EF 000016. Fixe o móvel na parede utilizando a ferragem EF 000146 e encaixe a capa plastica.
Drill the wall and insert hardware EF 000016. Attach the furniture on the wall using hardware EF 000146 and fit the plastic cover.
Perfore la pared y añade el herraje EF 000016. Fije el mueble en la pared utilizando el herraje EF 000146 y añade la capa plastica.

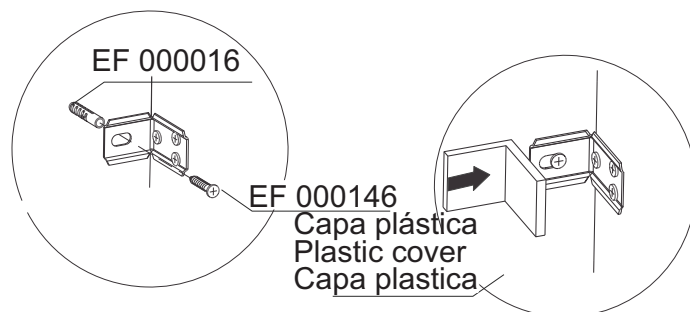
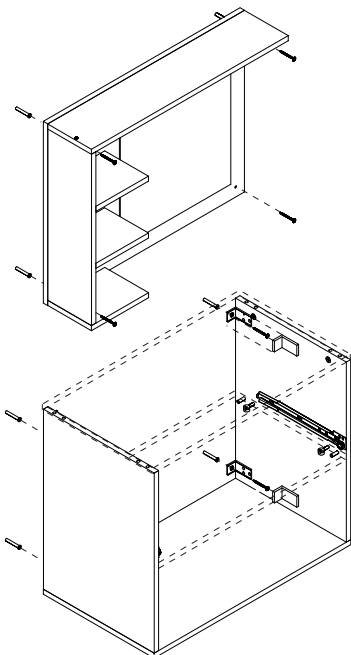

PASSO 17 / STEP 17 / PASO 17

Utilize o tapa furos para cobrir os parafusos aparentes.
Use the sticker to cover the apparent screws.
Utilice los tapa huecos para cubrir los tornillos aparentes.

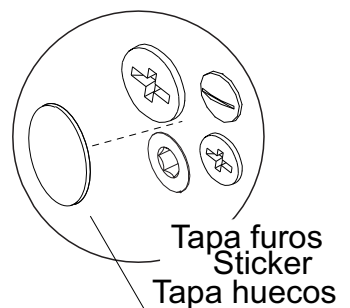
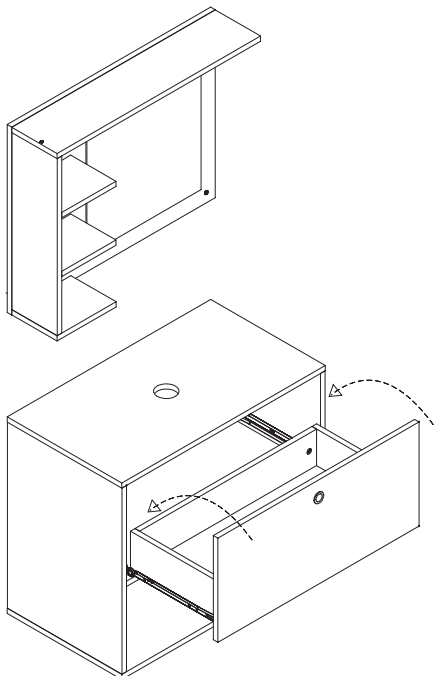

PASSO 18 / STEP 18 / PASO 18

Utilize o giz para dar o acabamento final ao produto.
Use the chalk to give the final finish on the product.
Utilize la tiza para dar el acabado final al producto.

